

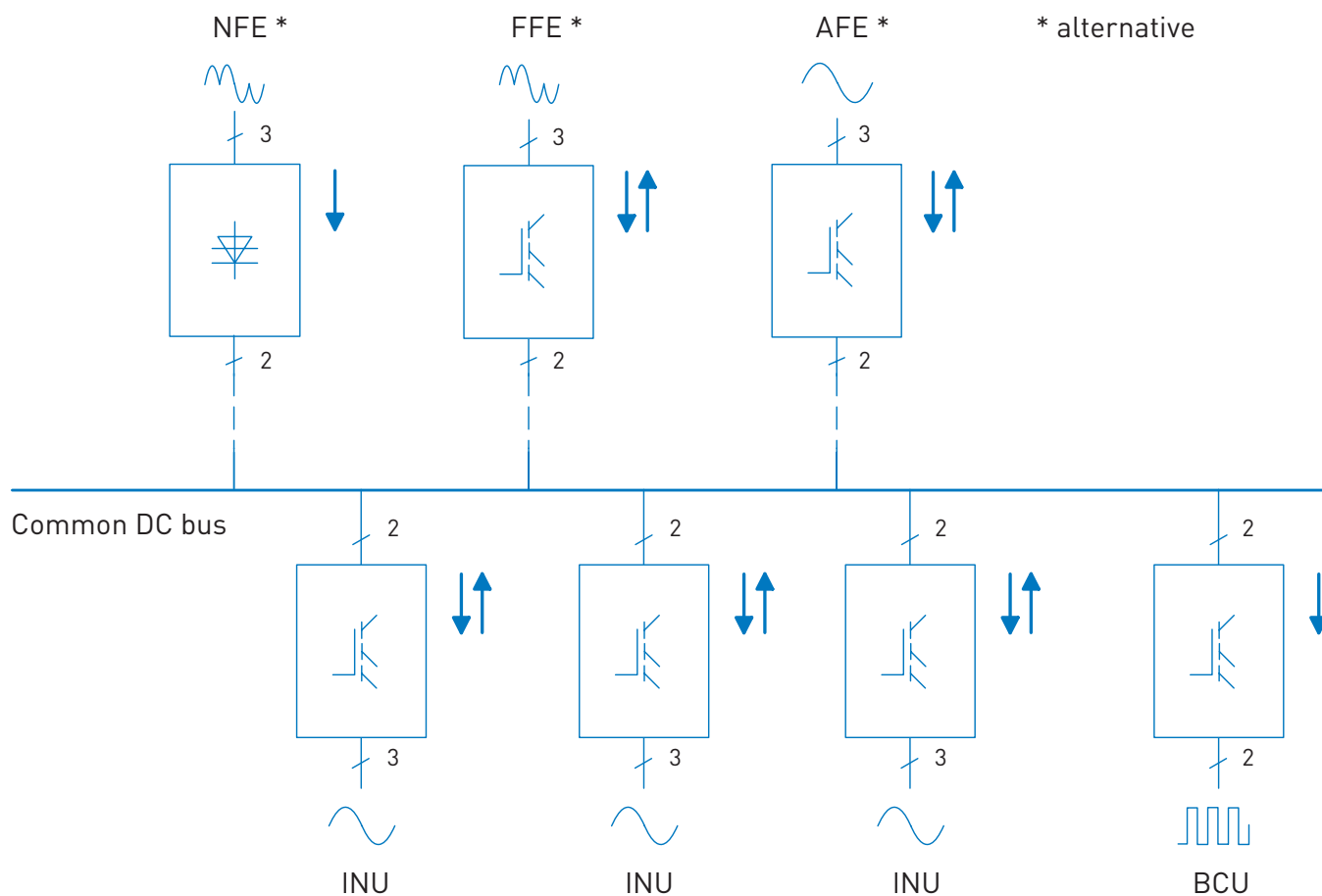

**VACON NX PRODUCTS
FOR COMMON DC BUS SYSTEMS**

vaccon
DRIVEN BY DRIVES

HIGH CONFIGURABILITY



Vacon offers a comprehensive range of common DC bus drive products. The product family covers a number of front-end units, inverter units and brake chopper units in the entire power range from 1 to 2000 kW at 380 VAC to 690 VAC. The drive components are built on the Vacon NX technology.

Common DC bus components are used in a multitude of combinations. In a typical DC bus configuration, the drives which are braking can transfer the energy directly to the drives in motoring mode.



FR4



FR6



FR7



FR8

Front-end units

The front-end units convert a mains AC voltage and current into a DC voltage and current. The power is transferred from the mains to a common DC bus (and, in certain cases, vice versa).

The AFE (Active front-end) unit is a bidirectional (regenerative) power converter for the front-end of a common DC bus drive line-up. An external LCL filter is used at the input. This unit is suitable in applications where low mains harmonics are required.

The FFE (Fundamental front-end) unit is a bidirectional (regenerative) power converter for the front-end of a common DC bus drive line-up. The FFE is a device that operates as a diode bridge for motoring power and like an anti-parallel thyristor bridge for regenerating power. In the FFE unit, IGBTs are used instead of thyristors. A dedicated external choke is used at the input. The FFE unit is suitable as a rectifying device when a "normal" level of harmonics is accepted but regeneration to the mains is required.

The NFE (Non-regenerative front-end) unit is a unidirectional (motoring) power converter for the front-end of a common DC bus drive line-up. The NFE is a device that operates as a diode bridge using diode/thyristor components. A dedicated external choke is used at the input. The NFE unit has the capacity to charge a common DC bus. This unit is suitable as a rectifying device when a "normal" level of harmonics is accepted and no regeneration to the mains is required.

Inverter unit

The INU (Inverter unit) is a bidirectional DC-fed power inverter for the supply and control of AC motors. The INU is supplied from a common DC bus drive line-up. A charging circuit is needed in case the connection possibility to a live DC bus is required. The DC side charging circuit is integrated up to 75 kW (FR4-FR8) and external for higher power ratings (FI9-FI14).

Brake chopper unit

The BCU (Brake chopper unit) is a unidirectional power converter for the supply of excessive energy from a common DC bus drive line-up to resistors where the energy is dissipated as heat. External resistors are needed.



FI9



FI10



FI12



FI13

SELECTING COMMON DC BUS FRONT-ENDS

The Vacon common DC bus product portfolio fulfills all solution demands with a flexible architecture.

Vacon front-end units are selected according to the level of harmonics and power requirements. Typical drive system configurations are illustrated below.

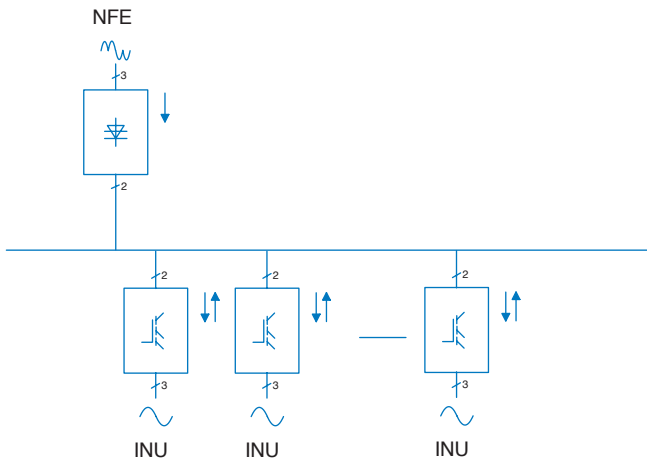

NFE + INUs

- low total mains power, $P_{\text{mains}} \leq \sum P_{\text{INU}}$
- suitable e.g. for small processing line with un- and recoiler, em-stop coasting

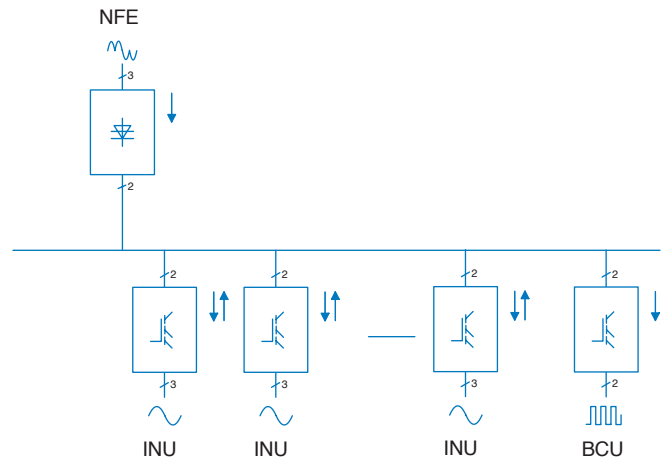

NFEs + INUs + BCU

- high total mains power, $P_{\text{mains}} \leq \sum P_{\text{INU}}$, short time small power braking
- suitable e.g. for big processing line or PM (dry end)

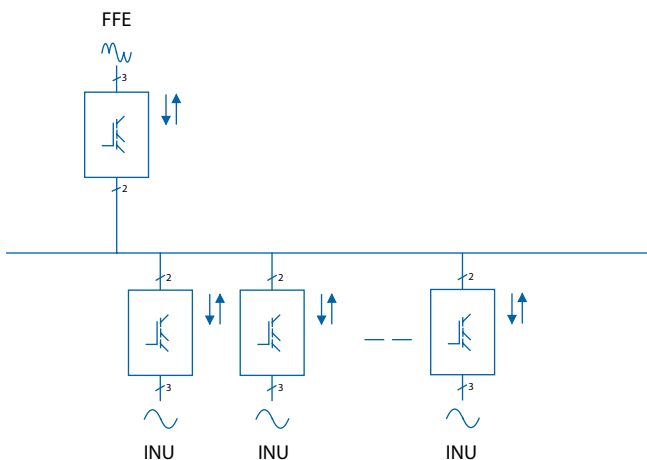

FFE + INUs

- high total mains power, $-P_{\text{mains}} \approx +P_{\text{mains}}$, $P_{\text{mains}} \leq \sum P_{\text{INU}}$
- suitable e.g. for process line or PM

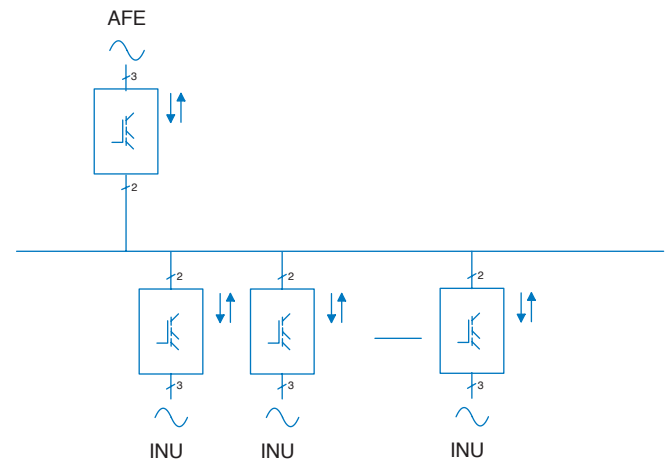

AFE + INUs

- low harmonics, $-P_{\text{mains}} \approx +P_{\text{mains}}$, $P_{\text{mains}} \leq \sum P_{\text{INU}}$
- suitable for almost every applications

	NFE Non-regenerative front-end	FFE Fundamental front-end	AFE Active front-end	Conventional regenerative front-end *)
Input device	Choke (L)	Choke (L)	Filter (LCL)	Choke or auto-transformer (L)
Bridge type	Diode/thyristor bridge	IGBT bridge, two-level type	IGBT bridge, two-level type	Anti-parallel connected thyristor bridge
Type of operation	Controlled half-bridge	Average switching frequency approx. equivalent to line frequency	High frequency modulation (1.5 to 3.6 kHz)	Firing angle controlled
Direction of power	Motoring	Motoring and regenerating	Motoring and regenerating	Motoring and regenerating
Charging	Constant current	External required	External required	Usually internal
DC voltage	Nominal (approx. $1.35 * U_N$)	Nominal (approx. $1.35 * U_N$)	Stable at +10% of nominal (approx. 110% of $1.35 * U_N$).	Lowered DC voltage for commutation margin (e.g. 17% fi approx. 83% of $1.35 * U_N$) or autotransformer on regenerative bridge
THD	Similar to 6-pulse bridge, normally < 40%	Similar to 6-pulse bridge, normally < 40%	Very low	Similar to 6-pulse bridge or worse

*) Conventional regenerative front-end (aka "Anti-parallel thyristor bridge") is not available from Vacon.

TYPICAL DEVICE CONFIGURATIONS

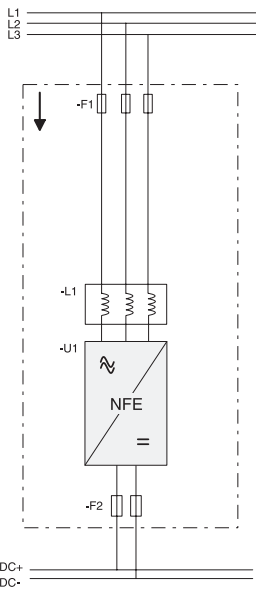

NON-REGENERATIVE FRONT-END

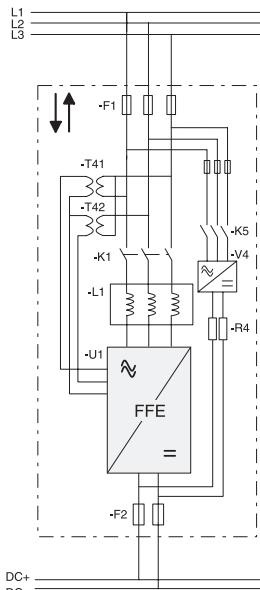

FUNDAMENTAL FRONT-END

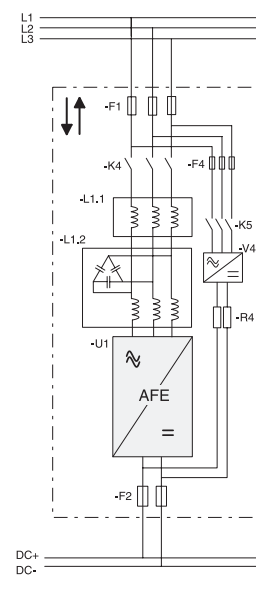

ACTIVE FRONT-END

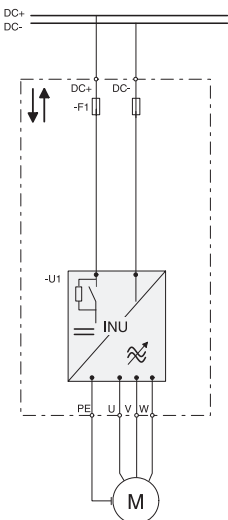

INVERTER UNIT (FR4-FR8)

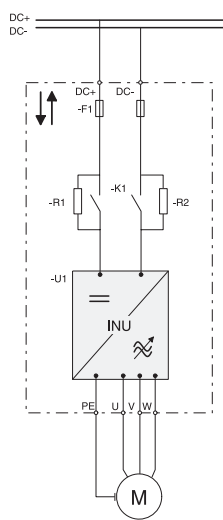

INVERTER UNIT (FI9-FI14)

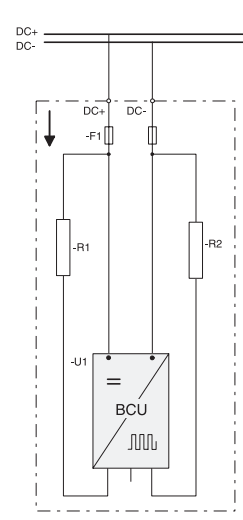

BRAKE CHOPPER UNIT

ELECTRICAL RATINGS

380–500 VAC

Type	Unit		Low overload (AC current)		High overload (AC current)		I _{max}
	Code	Frame	I _{L-cont} [A]	I _{1min} [A]	I _{H-cont} [A]	I _{1min} [A]	I _{2s} [A]
INU	NXI_0004 5	FR4	4,3	4,7	3,3	5,0	6,2
	NXI_0009 5	FR4	9	9,9	7,6	11,4	14
	NXI_0012 5	FR4	12	13,2	9	13,5	18
	NXI_0016 5	FR6	16	17,6	12	18	24
	NXI_0022 5	FR6	23	25,3	16	24	32
	NXI_0031 5	FR6	31	34	23	35	46
	NXI_0038 5	FR6	38	42	31	47	62
	NXI_0045 5	FR6	46	51	38	57	76
	NXI_0061 5	FR7	61	67	46	69	92
	NXI_0072 5	FR7	72	79	61	92	122
	NXI_0087 5	FR7	87	96	72	108	144
	NXI_0105 5	FR7	105	116	87	131	174
	NXI_0140 5	FR8	140	154	105	158	210
	NXI_0168 5	FI9	170	187	140	210	280
	NXI_0205 5	FI9	205	226	170	255	336
	NXI_0261 5	FI9	261	287	205	308	349
	NXI_0300 5	FI9	300	330	245	368	444
	NXI_0385 5	FI10	385	424	300	450	540
	NXI_0460 5	FI10	460	506	385	578	693
	NXI_0520 5	FI10	520	572	460	690	828
	NXI_0590 5	FI12	590	649	520	780	936
	NXI_0650 5	FI12	650	715	590	885	1062
	NXI_0730 5	FI12	730	803	650	975	1170
	NXI_0820 5	FI12	820	902	730	1095	1314
	NXI_0920 5	FI12	920	1012	820	1230	1476
	NXI_1030 5	FI12	1030	1133	920	1380	1656
	NXI_1150 5	FI13	1150	1265	1030	1545	1854
NXI_1300 5	FI13	1300	1430	1150	1725	2070	
NXI_1450 5	FI13	1450	1595	1300	1950	2340	
NXI_1770 5	FI14	1770	1947	1600	2400	2880	
NXI_2150 5	FI14	2150	2365	1940	2910	3492	
NXI_2700 5	FI14	2700	2970	2300	3278	3933	
AFE	NXA_0261 5	FI9	261	287	205	308	349
	NXA_0460 5	FI10	460	506	385	578	693
	NXA_0920 5	FI12	920	1012	820	1230	1476
	NXA_1300 5	FI13	1300	1430	1150	1725	2070
	NXA_2150 5	FI14	2150	2365	1940	2910	3492
FFE	NXF_0300 5	FI9	300	330	245	368	444
	NXF_0520 5	FI10	520	572	460	690	828
	NXF_1030 5	FI12	1030	1133	920	1380	1656
	NXF_1450 5	FI13	1450	1595	1300	1950	2340
	NXF_2700 5	FI14	2700	2970	2300	3278	3933
NFE	NXN_0400 5	FI9	400	440	312	488	592
	NXN_0520 5	FI9	520	572	460	690	828
	NXN_0600 5	FI9	600	660	510	732	888
BCU	NXB_0012 5	FR4	24	24	24	24	24
	NXB_0045 5	FR6	90	90	90	90	90
	NXB_0105 5	FR7	210	210	210	210	210
	NXB_0300 5	FI9	600	600	600	600	600

Please note that the currents in the BCU are total braking currents.

525–690 VAC

Type	Unit		Low overload (AC current)		High overload (AC current)		I _{max}
	Code	Frame	I _{L-cont} [A]	I _{1min} [A]	I _{H-cont} [A]	I _{1min} [A]	I _{2s} [A]
INU	NXI_0004 6	FR6	4,5	5	3,2	5	6,4
	NXI_0005 6	FR6	5,5	6	4,5	7	9
	NXI_0007 6	FR6	7,5	8	5,5	8	11
	NXI_0010 6	FR6	10	11	7,5	11	15
	NXI_0013 6	FR6	13,5	15	10	15	20
	NXI_0018 6	FR6	18	20	13,5	20	27
	NXI_0022 6	FR6	22	24	18	27	36
	NXI_0027 6	FR6	27	30	22	33	44
	NXI_0034 6	FR6	34	37	27	41	54
	NXI_0041 6	FR7	41	45	34	51	68
	NXI_0052 6	FR7	52	57	41	62	82
	NXI_0062 6	FR8	62	68	52	78	104
	NXI_0080 6	FR8	80	88	62	93	124
	NXI_0100 6	FR8	100	110	80	120	160
	NXI_0125 6	FI9	125	138	100	150	200
	NXI_0144 6	FI9	144	158	125	188	213
	NXI_0170 6	FI9	170	187	144	216	245
	NXI_0208 6	FI9	208	229	170	255	289
	NXI_0261 6	FI10	261	287	208	312	375
	NXI_0325 6	FI10	325	358	261	392	470
	NXI_0385 6	FI10	385	424	325	488	585
	NXI_0416 6	FI10	416	458	325	488	585
	NXI_0460 6	FI12	460	506	385	578	693
	NXI_0502 6	FI12	502	552	460	690	828
	NXI_0590 6	FI12	590	649	502	753	904
	NXI_0650 6	FI12	650	715	590	885	1062
	NXI_0750 6	FI12	750	825	650	975	1170
	NXI_0820 6	FI12	820	902	650	975	1170
NXI_0920 6	FI13	920	1012	820	1230	1476	
NXI_1030 6	FI13	1030	1133	920	1380	1656	
NXI_1180 6	FI13	1180	1298	1030	1464	1755	
NXI_1500 6	FI14	1500	1650	1300	1950	2340	
NXI_1900 6	FI14	1900	2090	1500	2250	2700	
NXI_2250 6	FI14	2250	2475	1900	2782	3335	
AFE	NXA_0170 6	FI9	170	187	144	216	245
	NXA_0385 6	FI10	385	424	325	488	585
	NXA_0750 6	FI12	750	825	650	975	1170
	NXA_1030 6	FI13	1030	1133	920	1380	1656
	NXA_1900 6	FI14	1900	2090	1500	2250	2700
FFE	NXF_0208 6	FI9	208	229	170	255	289
	NXF_0416 6	FI10	416	458	325	488	585
	NXF_0820 6	FI12	820	902	650	975	1170
	NXF_1180 6	FI13	1180	1298	1030	1464	1755
	NXF_2250 6	FI14	2250	2475	1900	2782	3335
NFE	NXN_0400 6	FI9	400	440	312	488	592
	NXN_0520 6	FI9	520	572	460	690	828
	NXN_0600 6	FI9	600	660	510	732	888
BCU	NXB_0034 6	FR6	68	68	68	68	68
	NXB_0052 6	FR7	104	104	104	104	104
	NXB_0208 6	FI9	416	416	416	416	416

Please note that the currents in the BCU are total braking currents.

DIMENSIONS AND FUSES

380–500 VAC

Module			Module dimensions				Input fuses				
Type	Code	Frame	Height (mm)	Width (mm)	Depth (mm)	Weight (kg)	Busman fuse type (aR)	Size	U _N (V)	I _N (A)	Q'ty
INU	NXI_0004 5	FR4	292	128	190	5	170M1560	000	690	20	2
	NXI_0009 5	FR4	292	128	190	5	170M1562	000	690	63	2
	NXI_0012 5	FR4	292	128	190	5	170M1562	000	690	63	2
	NXI_0016 5	FR6	519	195	237	16	170M1565	000	690	63	2
	NXI_0022 5	FR6	519	195	237	16	170M1565	000	690	63	2
	NXI_0031 5	FR6	519	195	237	16	170M1565	000	690	63	2
	NXI_0038 5	FR6	519	195	237	16	170M1567	000	690	100	2
	NXI_0045 5	FR6	519	195	237	16	170M1567	000	690	100	2
	NXI_0061 5	FR7	591	237	257	29	170M1568	000	690	125	2
	NXI_0072 5	FR7	591	237	257	29	170M1570	000	690	200	2
	NXI_0087 5	FR7	591	237	257	29	170M1570	000	690	200	2
	NXI_0105 5	FR7	591	237	257	29	170M1571	000	690	250	2
	NXI_0140 5	FR8	758	289	344	48	170M3819	DIN1	690	400	2
	NXI_0168 5	FI9	1030	239	372	67	170M3819	DIN1	690	400	2
	NXI_0205 5	FI9	1030	239	372	67	170M3819	DIN1	690	400	2
	NXI_0261 5	FI9	1030	239	372	67	170M6812	DIN3	690	800	2
	NXI_0300 5	FI9	1030	239	372	67	170M6812	DIN3	690	800	2
	NXI_0385 5	FI10	1032	239	552	100	170M8547	3SHT	690	1250	2
	NXI_0460 5	FI10	1032	239	552	100	170M8547	3SHT	690	1250	2
	NXI_0520 5	FI10	1032	239	552	100	170M8547	3SHT	690	1250	2
	NXI_0590 5	FI12	1032	2 × 239	552	200	170M8547	3SHT	690	1250	2 × 2
	NXI_0650 5	FI12	1032	2 × 239	552	200	170M8547	3SHT	690	1250	2 × 2
	NXI_0730 5	FI12	1032	2 × 239	552	200	170M8547	3SHT	690	1250	2 × 2
	NXI_0820 5	FI12	1032	2 × 239	552	200	170M8547	3SHT	690	1250	2 × 2
	NXI_0920 5	FI12	1032	2 × 239	552	200	170M8547	3SHT	690	1250	2 × 2
	NXI_1030 5	FI12	1032	2 × 239	552	200	170M8547	3SHT	690	1250	2 × 2
	NXI_1150 5	FI13	1032	708	553	306	170M8547	3SHT	690	1250	6
NXI_1300 5	FI13	1032	708	553	306	170M8547	3SHT	690	1250	6	
NXI_1450 5	FI13	1032	708	553	306	170M8547	3SHT	690	1250	6	
NXI_1770 5	FI14	1032	2 × 708	553	612	170M8547	3SHT	690	1250	2 × 6	
NXI_2150 5	FI14	1032	2 × 708	553	612	170M8547	3SHT	690	1250	2 × 6	
NXI_2700 5	FI14	1032	2 × 708	553	612	170M8547	3SHT	690	1250	2 × 6	
AFE	NXA_0261 5	FI9	1030	239	372	67	170M6202	3SHT	1250	500	3
	NXA_0460 5	FI10	1032	239	552	100	170M6277	3SHT	1250	1000	3
	NXA_0920 5	FI12	1032	2 × 239	552	200	170M6277	3SHT	1250	1000	3 × 2
	NXA_1300 5	FI13	1032	708	553	306	170M6277	3SHT	1250	1000	3 × 3
	NXA_2150 5	FI14	1032	2 × 708	553	612	170M6305	3SHT	1250	700	2 × 3 × 3
FFE	NXF_0300 5	FI9	1030	239	372	67	170M6305	3SHT	1250	700	3
	NXF_0520 5	FI10	1032	239	552	100	170M6277	3SHT	1250	1000	3
	NXF_1030 5	FI12	1032	2 × 239	552	200	170M6277	3SHT	1250	1000	2 × 3
	NXF_1450 5	FI13	1032	708	553	306	170M6277	3SHT	1250	1000	3 × 3
	NXF_2700 5	FI14	1032	2 × 708	553	612	170M6277	3SHT	1250	1000	2 × 3 × 3
NFE	NXN_0400 5	FI9	1030	239	372	67	170M5813	DIN2	690	700	3
	NXN_0520 5	FI9	1030	239	372	67	170M8547	3SHT	690	1250	3
	NXN_0600 5	FI9	1030	239	372	67	170M8547	3SHT	690	1250	3
BCU	NXB_0012 5	FR4	292	128	190	5	170M1565	000	690	63	2
	NXB_0045 5	FR6	519	195	237	16	170M1570	000	690	200	2
	NXB_0105 5	FR7	591	237	257	29	170M3819	DIN1	690	400	2
	NXB_0300 5	FI9	1030	239	372	67	170M8547	3SHT	690	1250	2

Please note that SHT fuses can be assembled into same-size DIN fuse base.

525–690 VAC

Module			Module dimensions				Input fuses				
Type	Code	Frame	Height (mm)	Width (mm)	Depth (mm)	Weight (kg)	Bussman fuse type (aR)	Size	U _N (V)	I _N (A)	Q'ty
INU	NXI_0004 6	FR6	519	195	237	16	170M2673	00	1000	20	2
	NXI_0005 6	FR6	519	195	237	16	170M2673	00	1000	20	2
	NXI_0007 6	FR6	519	195	237	16	170M2673	00	1000	20	2
	NXI_0010 6	FR6	519	195	237	16	170M2673	00	1000	20	2
	NXI_0013 6	FR6	519	195	237	16	170M2679	00	1000	63	2
	NXI_0018 6	FR6	519	195	237	16	170M2679	00	1000	63	2
	NXI_0022 6	FR6	519	195	237	16	170M2679	00	1000	63	2
	NXI_0027 6	FR6	519	195	237	16	170M2679	00	1000	63	2
	NXI_0034 6	FR6	519	195	237	16	170M2683	00	1000	160	2
	NXI_0041 6	FR7	591	237	257	29	170M2683	00	1000	160	2
	NXI_0052 6	FR7	591	237	257	29	170M2683	00	1000	160	2
	NXI_0062 6	FR8	758	289	344	48	170M2683	00	1000	160	2
	NXI_0080 6	FR8	758	289	344	48	170M4199	1SHT	1250	400	2
	NXI_0100 6	FR8	758	289	344	48	170M4199	1SHT	1250	400	2
	NXI_0125 6	FI9	1030	239	372	67	170M4199	1SHT	1250	400	2
	NXI_0144 6	FI9	1030	239	372	67	170M4199	1SHT	1250	400	2
	NXI_0170 6	FI9	1030	239	372	67	170M4199	1SHT	1250	400	2
	NXI_0208 6	FI9	1030	239	372	67	170M4199	1SHT	1250	400	2
	NXI_0261 6	FI10	1032	239	552	100	170M6305	3SHT	1250	700	2
	NXI_0325 6	FI10	1032	239	552	100	170M6305	3SHT	1250	700	2
	NXI_0385 6	FI10	1032	239	552	100	170M6277	3SHT	1250	1000	2
	NXI_0416 6	FI10	1032	239	552	100	170M6277	3SHT	1250	1000	2
	NXI_0460 6	FI12	1032	2 × 239	552	200	170M6305	3SHT	1250	700	2 × 2
	NXI_0502 6	FI12	1032	2 × 239	552	200	170M6305	3SHT	1250	700	2 × 2
	NXI_0590 6	FI12	1032	2 × 239	552	200	170M6305	3SHT	1250	700	2 × 2
	NXI_0650 6	FI12	1032	2 × 239	552	200	170M6277	3SHT	1250	1000	2 × 2
	NXI_0750 6	FI12	1032	2 × 239	552	200	170M6277	3SHT	1250	1000	2 × 2
	NXI_0820 6	FI12	1032	2 × 239	552	200	170M6277	3SHT	1250	1000	2 × 2
NXI_0920 6	FI13	1032	708	553	306	170M6305	3SHT	1250	700	6	
NXI_1030 6	FI13	1032	708	553	306	170M6277	3SHT	1250	1000	6	
NXI_1180 6	FI13	1032	708	553	306	170M6277	3SHT	1250	1000	6	
NXI_1500 6	FI14	1032	2 × 708	553	612	170M6305	3SHT	1250	700	2 × 6	
NXI_1900 6	FI14	1032	2 × 708	553	612	170M6277	3SHT	1250	1000	2 × 6	
NXI_2250 6	FI14	1032	2 × 708	553	612	170M6277	3SHT	1250	1000	2 × 6	
AFE	NXA_0170 6	FI9	1030	239	372	67	170M4199	1SHT	1250	400	3
	NXA_0385 6	FI10	1032	239	552	100	170M6305	3SHT	1250	700	3
	NXA_0750 6	FI12	1032	2 × 239	552	200	170M6305	3SHT	1250	700	2 × 3
	NXA_1030 6	FI13	1032	708	553	306	170M6305	3SHT	1250	700	3 × 3
	NXA_1900 6	FI14	1032	2 × 708	553	612	170M6277	3SHT	1100	1000	2 × 3 × 3
FFE	NXF_0208 6	FI9	1030	239	372	67	170M4199	1SHT	1250	400	3
	NXF_0416 6	FI10	1032	239	552	100	170M6305	3SHT	1250	700	3
	NXF_0820 6	FI12	1032	2 × 239	552	200	170M6277	3SHT	1100	1000	2 × 3
	NXF_1180 6	FI13	1032	708	553	306	170M6277	3SHT	1100	1000	2 × 2 × 3
	NXF_2250 6	FI14	1032	2 × 708	553	612	170M6305	3SHT	1250	700	2 × 3 × 3
NFE	NXN_0400 6	FI9	1030	239	372	67	170M5813	DIN2	690	700	3
	NXN_0520 6	FI9	1030	239	372	67	170M8547	3SHT	690	1250	3
	NXN_0600 6	FI9	1030	239	372	67	170M8547	3SHT	690	1250	3
BCU	NXB_0034 6	FR6	519	195	237	16	170M2683	00	1000	160	2
	NXB_0052 6	FR7	591	237	257	29	170M4199	1SHT	1250	400	2
	NXB_0208 6	FI9	1030	239	372	67	170M6277	3SHT	1250	1000	4

Please note that SHT fuses can be assembled into same-size DIN fuse base.

Standard features	INU					AFE		FFE	NFE	BCU				
	NXI AAAAA V					NXA AAAAA V		NXF AAAAA V	NXN AAAAA V	NXB AAAAA V				
	FR4, 6, 7	FR8	FI9...	FR7	FR8, FI9...	FI9...	FI9...	FR4, 6, 7	FI9					
IP00		●	●		●		●	●		●	●			
IP21	●			●						●				
Air cooling	●	●	●	●	●	●	●	●	●	●	●			
Standard board	●	●	●	●	●	●	●	●	●	●	●			
Varnished board									●					
Alphanumeric keypad	●	●	●	●	●	●	●	●	●	●	●			
EMC class T (EN 61800-3 for IT networks)	●	●	●	●	●	●	●	●	●	●	●			
Safety CE / UL	●	●	●	●	●	●	●	●	●	●	●			
Input choke							○	○						
LCL filter				○	○									
No integrated charging			●	●	●	●					●			
Integrated charging (DC side)	●	●							●	●				
Diode/thyristor rectifier									●					
IGBT	●	●	●	●	●	●	●	●	●	●	●			
Standard I/O	Card slot					Number of I/O channels								
	A	B	C	D	E									
OPT-A1 Binary input (24 VDC)						6	6	6	6	6	6	n/a	6	6
OPT-A1 Binary output (24 VDC)						1	1	1	1	1	1	n/a	1	1
OPT-A1 Analog input						2	2	2	2	2	2	n/a	2	2
OPT-A1 Analog output						1	1	1	1	1	1	n/a	1	1
OPT-D7 Voltage measurement						-	-	-	-	-	2	n/a	-	-
OPT-A2 Relay output (NO/NC)						2	2	2	2	2	2	2 (NO)	2	2
Options														
Optional I/O cards														
OPT-A3 Relay output + Thermistor input						○	○	○	○	○	○	n/a	○	○
OPT-A4 Encoder TTL type						○	○	○	-	-	-	n/a	-	-
OPT-A5 Encoder HTL type						○	○	○	-	-	-	n/a	-	-
OPT-A7 Double encoder HTL type						○	○	○	-	-	-	n/a	-	-
OPT-A8 I/O as OPT-A1 (galvanic isolation)						○	○	○	○	○	○	n/a	○	○
OPT-A9 I/O as OPT-A1 (2.5 mm ² terminals)						○	○	○	○	○	○	n/a	○	○
OPT-AE Encoder HTL type (Divider + direction)						○	○	○	-	-	-	n/a	-	-
¹⁾ OPT-AF Safe disable EN954-1, cat 3						○	○	○	-	-	-	n/a	-	-
I/O expander cards (OPT-B)														
OPT-B1 Selectable I/O						○	○	○	○	○	○	n/a	○	○
OPT-B2 Relay output						○	○	○	○	○	○	n/a	○	○
OPT-B4 Analog input/output						○	○	○	○	○	○	n/a	○	○
OPT-B5 Relay output						○	○	○	○	○	○	n/a	○	○
OPT-B8 PT100						○	○	○	○	○	○	n/a	○	○
OPT-B9 Binary input + R0						○	○	○	○	○	○	n/a	○	○
OPT-BB + EnDat + Sin/Cos 1 Vp-p						○	○	○	-	-	-	n/a	-	-
OPT-BC Encoder out = Resolver simulation						○	○	○	-	-	-	n/a	-	-
Fieldbus cards (OPT-C)														
OPT-C2 RS-485 (Multiprotocol)						○	○	○	○	○	○	n/a	○	○
OPT-C3 Profibus DP						○	○	○	○	○	○	n/a	○	○
OPT-C4 LonWorks						○	○	○	○	○	○	n/a	○	○
OPT-C5 Profibus DP (D9-type connector)						○	○	○	○	○	○	n/a	○	○
OPT-C6 CANopen (slave)						○	○	○	○	○	○	n/a	○	○
OPT-C7 DeviceNet						○	○	○	○	○	○	n/a	○	○
OPT-C8 RS-485 (Multiprotocol, D9-type connector)						○	○	○	○	○	○	n/a	○	○
OPT-CF CAN / Euromap						○	○	○	○	○	○	n/a	○	○
OPT-CG SELMA 2 protocol (SAMI)						○	○	○	○	○	○	n/a	○	○
OPT-CI Ethernet (Modbus/TCP)						○	○	○	○	○	○	n/a	○	○
Communication cards (OPT-D)														
OPT-D1 System Bus adapter (2 x fiber optic pairs)						○	○	○	○	○	○	n/a	○	○
OPT-D2 System Bus adapter (1 x fiber optic pair) & CAN-bus adapter (galvanically decoupled)						○	○	○	○	○	○	n/a	○	○
OPT-D3 RS232 adapter card (galvanically decoupled), used mainly for application engineering to connect another keypad						○	○	○	○	○	○	n/a	○	○
OPT-D6 CAN-bus adapter (galvanically decoupled)						○	○	○	○	○	○	n/a	○	○
OPT-D7 Voltage measurement card						○	○	○	○	○	-	n/a	○	○

¹⁾ Certification pending ● = included ○ = optional

Supply connection	Input voltage U_{in} (AC) Front-end modules	380-500 Vac / 525-690 Vac -10%...+10%
	Input voltage U_{in} (DC) Inverter and brake chopper modules	465...800 Vdc / 640...1100 Vdc. The waviness of the inverter supply voltage, formed in rectification of the electric network's alternating voltage in basic frequency, must be less than 50 V peak-to-peak
	Output voltage U_{out} (AC) Inverter	$3 - 0...U_{in} / 1.4$
	Output voltage U_{out} (DC) Active front-end module	$1.10 \times 1.35 \times U_{in}$ (Factory default)
	Output voltage U_{out} (DC) Fundamental and non-regenerative front-end module	$1.35 \times U_{in}$
Ambient conditions	Ambient operating temperature	-10°C (no frost)...+40°C: I_H -10°C (no frost)...+40°C: I_L
	Storage temperature	-40°C...+70°C
	Relative humidity	0 to 95% RH, non-condensing, non-corrosive, no dripping water
	Air quality: - chemical vapours - mechanical particles	IEC 721-3-3, unit in operation, class 3C2 IEC 721-3-3, unit in operation, class 3S2
	Altitude	100% load capacity (no derating) up to 1000 m 1% derating for each 100 m above 1000 m Max. altitudes: NX_2: 3000 m; NX_5: 3000 m; NX_6: 2000 m
	Vibration EN50178/EN60068-2-6	FR4...FR8: Displacement amplitude 1 mm (peak) at 5...15.8 Hz Max acceleration 1 G at 15.8...150 Hz FR9...F113: Displacement amplitude 0.25 mm (peak) at 5...31 Hz Max acceleration 1 G at 31...150 Hz
	Shock EN50178, EN60068-2-27	UPS Drop Test (for applicable UPS weights) Storage and shipping: max 15 G, 11 ms (in package)
	Cooling capacity required	approximately 2%
	Cooling air required	FR4 70 m³/h, FR6 425 m³/h, FR7 425 m³/h, FR8 650 m³/h FR9 1150 m³/h, FR10 1400 m³/h, FR11 2800 m³/h, FR12 2800 m³/h, FR13 4200 m³/h
	Unit enclosure class	FR8, FR9...14 (IP00); FR4...7 (IP21)
EMC (at default settings)	Immunity	Fulfils all EMC immunity requirements, level T
Safety		CE, UL, CUL, EN 61800-5-1 (2003), see unit nameplate for more detailed approvals
Control connections	Analogue input voltage	0...+10 V, $R_i = 200 \text{ k}\Omega$, [-10 V...+10 V joystick control] Resolution 0.1%, accuracy $\pm 1\%$
	Analogue input current	0(4)...20 mA, $R_i = 250 \text{ }\Omega$ differential
	Digital inputs	6, positive or negative logic; 18...30 VDC
	Auxiliary voltage	+24 V, $\pm 15\%$, max. 250 mA
	Output reference voltage	+10 V, +3%, max. load 10 mA
	Analogue output	0(4)...20 mA; R_L max. 500 Ω ; resolution 10 bits Accuracy $\pm 2\%$
	Digital outputs	Open collector output, 50 mA / 48 V
	Relay outputs	2 programmable change-over relay outputs Switching capacity: 24 VDC / 8 A, 250 VAC / 8 A, 125 VDC / 0.4 A Min. switching load: 5 V / 10 mA
Protections	Overvoltage protection	NX_5: 911 VDC; NX_6: 1200 VDC
	Undervoltage protection	NX_5: 333 VDC; NX_6: 460 VDC
	Earth fault protection	In case of earth fault in motor or motor cable, only the inverter is protected
	Motor phase supervision	Trips if any of the output phases is missing
	Overcurrent protection	Yes
	Unit overtemperature protection	Yes
	Motor overload protection	Yes
	Motor stall protection	Yes
	Motor underload protection	Yes
Short-circuit protection of +24 V and +10 V reference voltages	Yes	



Vacon Plc

Runsorintie 7, 65380 Vaasa, Finland
Tel. +358 (0)201 2121, Fax +358 (0)201 212 205
www.vacon.com, e-mail: info@vacon.com

Vacon Partner